

FISH DESCALING MACHINE

Application

Automatic descaling machine is designed to de-scale fish. It consists of metallic frame and stainless drum with interchangeable blades. It includes infeed shoot and outfeed shoot. Speed and angle of the drum can be adjusted according to the fish quality.

Main benefits

- High production rate
- Only 1 operator per machine
- Easily washable design

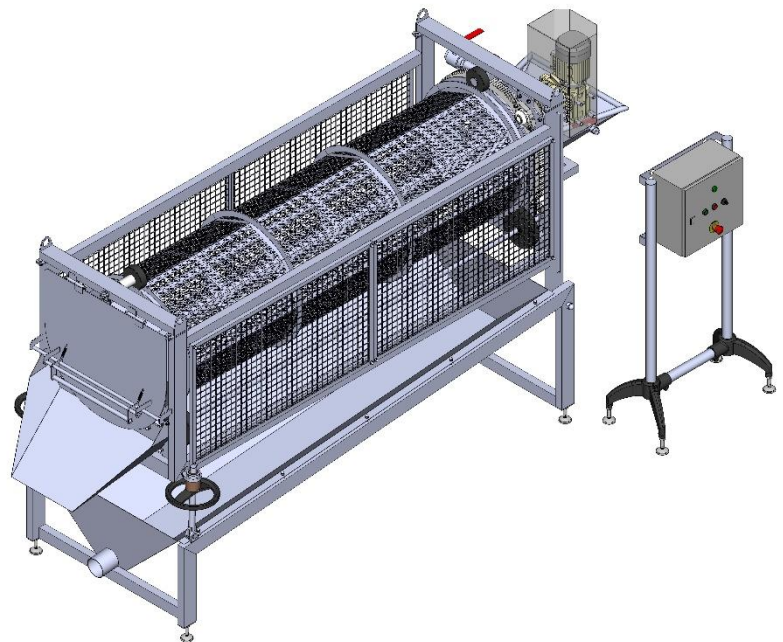

Operating principle

Fish is filled into the receiving tray and is delivered into the descaling drum. Descaling drum rotates and scrapes scales from fish and then deliver them to the exit tray.

Water is spraying on descaling drum to wash away removed scales. Removed scales and waste water goes into collection bath with drainage pipe at the end.

Processing capacity

	FISH DESCALING MACHINE (pieces/h)
170mm – 300mm	Up to 2,5 MT

*Equipment is adaptable to various size and weight dimensions

Technical characteristics

Product	Fish (sardines, sardinella etc.)
Processing capacity	Up to 2,5 MT per hour
Equipment dimension (LxWxH)	3500x1235x2050 (mm)
Number of operators on the machine	1
Key features	High capacity, continuous workflow

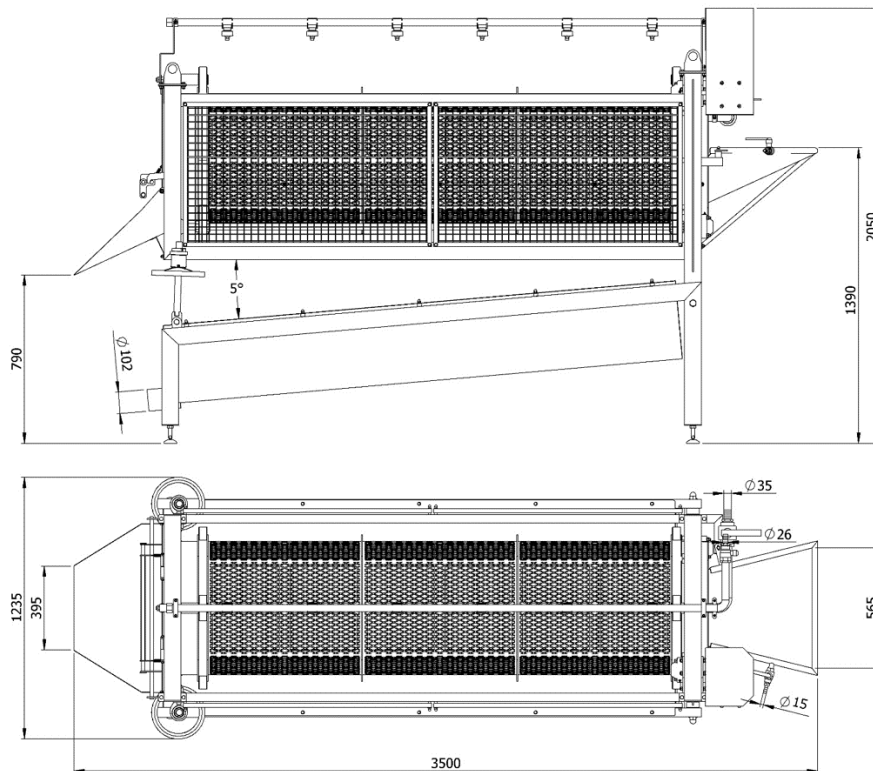

For more processing solutions

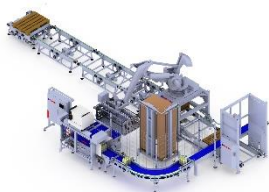

Full layer palletizer

Prepare palette within just 3 minutes!

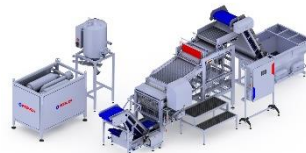

Drum-type nobbing line

Process small fish into quality product!



Autofeeder

Reduce your costs!

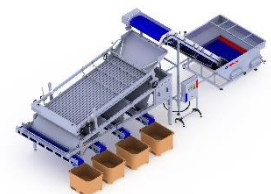

Roller grading line

Grading - a must for industrial processing of fish!